

The silent and stylish Element delivers the benefits of Big Ass Fans to air-conditioned spaces.

UNITING FORM AND FUNCTION

- **Airfoils and Winglets** — 10 anodized aluminum airfoils with black winglets (standard).
- **Gearless Direct Drive Motor** — Silent, permanent magnet motor with onboard electronics to eliminate electrical noise and interference; seamlessly integrates into building automation systems.
- **Extension Tube** — Standard 3 ft (0.9 m); optional 2 to 15 ft (0.6 to 4.6 m).
- **Functional Platform** — Integrate cameras, speakers, smoke detection, or just about anything else you can imagine.
- **Controller** — Wall-mounted control features an LCD display.
- **Environment** — Suitable for indoor spaces.
- **Colors** — Standard color options for Element are silver and black. Want something different? Individualize your fan with one of our 11 classic color upgrades, or work with our design consultants to create a shade that's all your own.
- **Efficiency** — Integrate Element into your HVAC system to improve air circulation and create a more cost-effective method of cooling and heating.

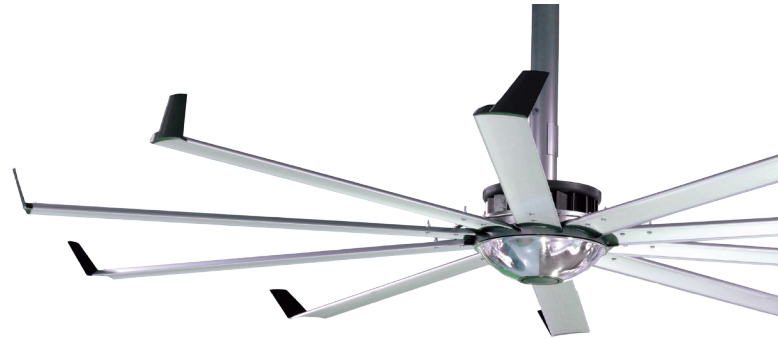

Standard Black Winglet



Functional Platform

Technical Specifications

Diameter (A)	Weight ¹	Max speed	Airfoil clearances ²	Input power and required breaker	Sound at max speed ³
16 ft (4.9 m)	258 lb (117 kg)	52 RPM	2 ft (0.6 m) on sides 3 ft (0.9 m) below ceiling deck	100–125 VAC, 1 Φ, 50/60 Hz, 10 A 200–250 VAC, 1 Φ, 50/60 Hz, 10 A	< 40 dBA
18 ft (5.5 m)	272 lb (123 kg)	43 RPM	2 ft (0.6 m) on sides 4 ft (1.2 m) below ceiling deck		
20 ft (6.1 m)	286 lb (130 kg)	33 RPM	2 ft (0.6 m) on sides 5 ft (1.5 m) below ceiling deck		

¹ Weight includes 3-ft (0.9-m) extension tube and upper mount.

² Suitable for ceilings as low as 12 feet (3.7 meters).

³ Fans are sound tested at maximum speed in a laboratory environment. Actual results in field conditions may vary due to sound reflecting surfaces and environmental conditions.

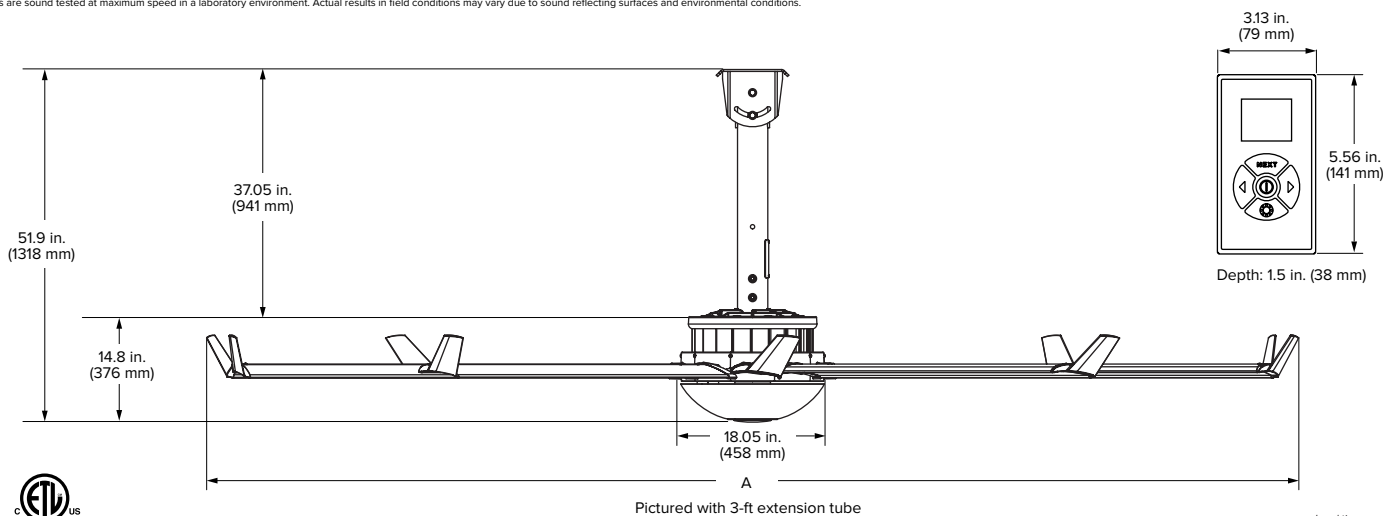

Pictured with 3-ft extension tube



Certified to UL 507 and CSA C22.2

Lead times may vary.
See full warranty for coverage information.
Specifications subject to change without notice.
Certifications listed here apply to the fan and do not include accessories.



AMERICAS
BIGASSOLUTIONS.COM
877-244-3267

CANADA
BIGASSOLUTIONS.COM/CA
844-924-4277

AUSTRALIA
BIGASSOLUTIONS.COM/AU
1-300-244-277

SINGAPORE
BIGASSOLUTIONS.COM/SG
+65 6709 8500

MALAYSIA
+603 5565 0888